

© International Baccalaureate Organization 2023

All rights reserved. No part of this product may be reproduced in any form or by any electronic or mechanical means, including information storage and retrieval systems, without the prior written permission from the IB. Additionally, the license tied with this product prohibits use of any selected files or extracts from this product. Use by third parties, including but not limited to publishers, private teachers, tutoring or study services, preparatory schools, vendors operating curriculum mapping services or teacher resource digital platforms and app developers, whether fee-covered or not, is prohibited and is a criminal offense.

More information on how to request written permission in the form of a license can be obtained from <https://ibo.org/become-an-ib-school/ib-publishing/licensing/applying-for-a-license/>.

© Organisation du Baccalauréat International 2023

Tous droits réservés. Aucune partie de ce produit ne peut être reproduite sous quelque forme ni par quelque moyen que ce soit, électronique ou mécanique, y compris des systèmes de stockage et de récupération d'informations, sans l'autorisation écrite préalable de l'IB. De plus, la licence associée à ce produit interdit toute utilisation de tout fichier ou extrait sélectionné dans ce produit. L'utilisation par des tiers, y compris, sans toutefois s'y limiter, des éditeurs, des professeurs particuliers, des services de tutorat ou d'aide aux études, des établissements de préparation à l'enseignement supérieur, des fournisseurs de services de planification des programmes d'études, des gestionnaires de plateformes pédagogiques en ligne, et des développeurs d'applications, moyennant paiement ou non, est interdite et constitue une infraction pénale.

Pour plus d'informations sur la procédure à suivre pour obtenir une autorisation écrite sous la forme d'une licence, rendez-vous à l'adresse <https://ibo.org/become-an-ib-school/ib-publishing/licensing/applying-for-a-license/>.

© Organización del Bachillerato Internacional, 2023

Todos los derechos reservados. No se podrá reproducir ninguna parte de este producto de ninguna forma ni por ningún medio electrónico o mecánico, incluidos los sistemas de almacenamiento y recuperación de información, sin la previa autorización por escrito del IB. Además, la licencia vinculada a este producto prohíbe el uso de todo archivo o fragmento seleccionado de este producto. El uso por parte de terceros —lo que incluye, a título enunciativo, editoriales, profesores particulares, servicios de apoyo académico o ayuda para el estudio, colegios preparatorios, desarrolladores de aplicaciones y entidades que presten servicios de planificación curricular u ofrezcan recursos para docentes mediante plataformas digitales—, ya sea incluido en tasas o no, está prohibido y constituye un delito.

En este enlace encontrará más información sobre cómo solicitar una autorización por escrito en forma de licencia: <https://ibo.org/become-an-ib-school/ib-publishing/licensing/applying-for-a-license/>.

# Physics

## Standard level

### Paper 1

2 May 2023

Zone A afternoon | Zone B morning | Zone C morning

45 minutes

---

#### Instructions to candidates

- Do not open this examination paper until instructed to do so.
- Answer all the questions.
- For each question, choose the answer you consider to be the best and indicate your choice on the answer sheet provided.
- A clean copy of the **physics data booklet** is required for this paper.
- The maximum mark for this examination paper is **[30 marks]**.

1. The graph shows the variation with time of the velocity of an object. Error bars for velocity are included.

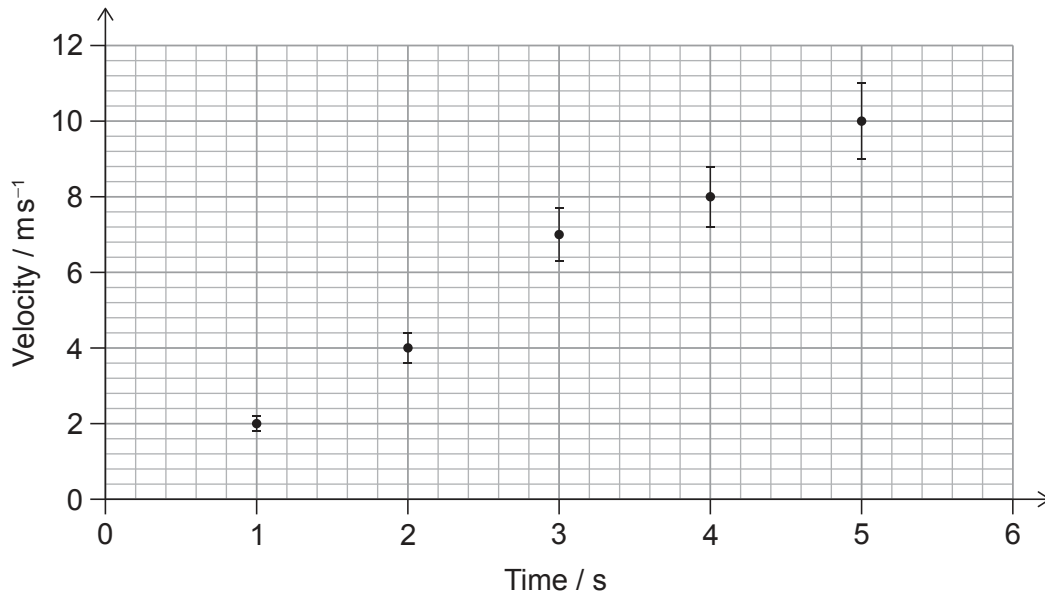

What is the percentage uncertainty for the velocity at time  $t = 4$  s?

- A.  $\pm 20\%$
  - B.  $\pm 10\%$
  - C.  $\pm 8\%$
  - D.  $\pm 5\%$
2. A toy car of mass 2 kg is at rest on a horizontal surface. A force of 30 N is applied to the toy car at time  $t = 0$ . Frictional forces of 10 N act on the toy car throughout its motion.

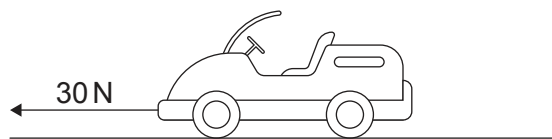

What is the speed of the toy car at  $t = 2$  s?

- A.  $10\text{ms}^{-1}$
- B.  $20\text{ms}^{-1}$
- C.  $30\text{ms}^{-1}$
- D.  $40\text{ms}^{-1}$

3. A stone is thrown vertically up from the top of a cliff with a velocity  $v$  at time  $t = 0$ . Air resistance is negligible.

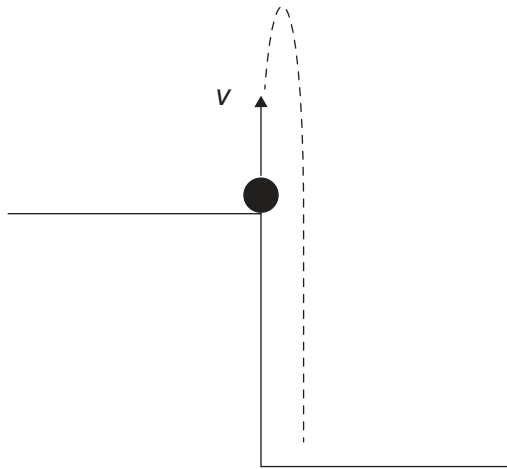

What is the variation with time of the velocity of the stone until it hits the ground?

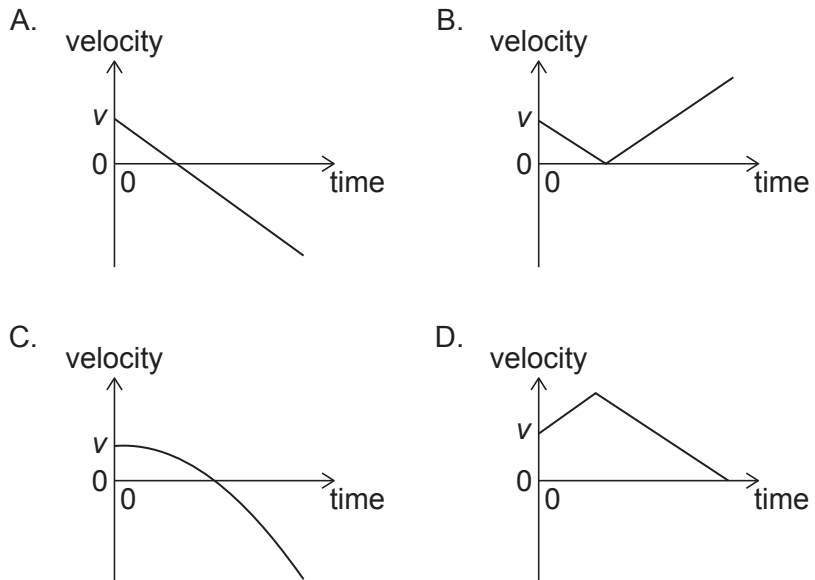

Turn over

4. Ball 1 is released at rest from the top of a building. At the same instant in time, Ball 2 is projected horizontally from the same height. The effect of air resistance is negligible.

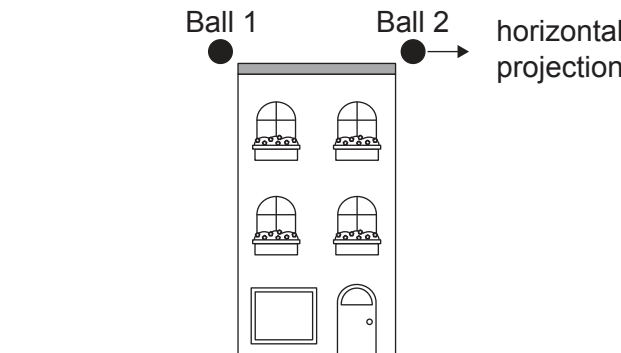

Which statement is true?

- A. The velocity on impact with the ground is the same for both balls.
- B. The time taken to hit the ground is greater for Ball 2.
- C. The speed on impact with the ground is the same for both balls.
- D. The velocity on impact with the ground is greater for Ball 2.
5. A variable force with a maximum  $F_{\max}$  is applied to an object over a time interval  $T$ . The object has a mass  $m$  and is initially at rest.

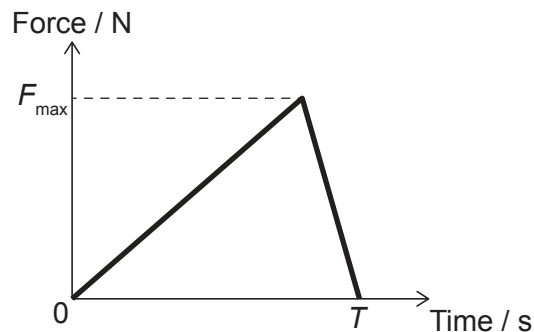

What is the speed of the object at time  $T$ ?

- A.  $\frac{F_{\max} T}{2m}$
- B.  $\frac{F_{\max} T}{m}$
- C.  $F_{\max} T m$
- D.  $2F_{\max} T m$

6. The angle  $\theta$  between a ramp and a horizontal surface slowly increases from zero. An object on the ramp does not slide as  $\theta$  increases.

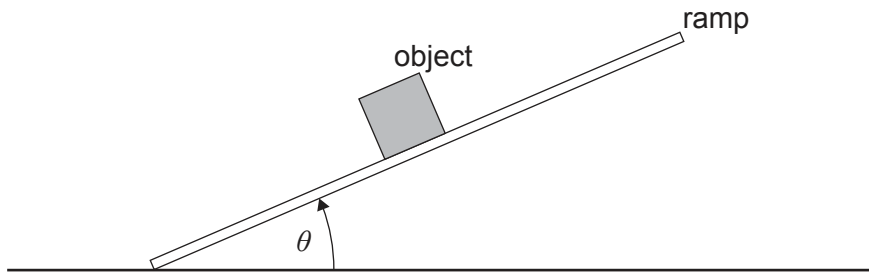

The frictional force on the object is

- A. constant.
  - B. negligible.
  - C. proportional to  $\cos \theta$ .
  - D. proportional to  $\sin \theta$ .
7. An object of mass  $M$  is accelerated vertically upwards by a motor at a constant acceleration. The object is initially at rest and reaches a vertical speed of  $4.0 \text{ m s}^{-1}$  in  $2.0 \text{ s}$ .

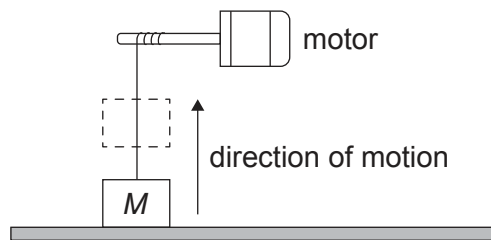

What is the average power output of the motor?

- A.  $8M$
- B.  $24M$
- C.  $32M$
- D.  $48M$

Turn over

8. An object is released from rest at X and slides to Y. The vertical distance between X and Y is 10 m. During the motion, 20% of the object's initial gravitational potential energy is lost as friction.

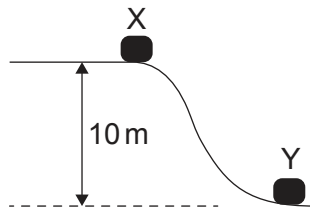

What is the speed of the object at Y?

- A.  $\frac{16}{\sqrt{g}}$
- B.  $2\sqrt{g}$
- C.  $4\sqrt{g}$
- D.  $8g$
9. The temperature of a gas increases from 100 K to 330 K. What is the change in temperature of the gas in degrees Celsius?
- A. 503
- B. 230
- C. –43
- D. –230
10. What is the internal energy of an ideal gas?
- A. The sum of the intermolecular potential energies of the molecules
- B. The energy required to raise the temperature by 1 K
- C. The sum of the kinetic energies of the molecules
- D. The energy required per kg to raise the temperature by 1 K

11. A vessel contains a mass  $X$  of helium gas and a mass  $2X$  of oxygen gas.

Molar mass of helium = 4 g

Molar mass of oxygen = 32 g

What is the  $\frac{\text{number of helium atoms}}{\text{number of oxygen molecules}}$  ?

- A.  $\frac{1}{8}$
  - B.  $\frac{1}{4}$
  - C. 4
  - D. 8
12. A balloon of volume  $V$  contains 10 mg of an ideal gas at a pressure  $P$ . An additional mass of the gas is added without changing the temperature of the balloon. This change causes the volume to increase to  $2V$  and the pressure to increase to  $3P$ .

What is the mass of gas **added** to the balloon?

- A. 5 mg
  - B. 15 mg
  - C. 50 mg
  - D. 60 mg
13. A mass is oscillating with simple harmonic motion. At time  $t$ , the acceleration is at a positive maximum.

What are the displacement and velocity of the mass at time  $t$ ?

	Displacement	Velocity
A.	positive maximum	zero
B.	negative maximum	zero
C.	positive maximum	negative maximum
D.	negative maximum	negative maximum

Turn over



14. A standing wave is formed between two loudspeakers that emit sound waves of frequency  $f$ .

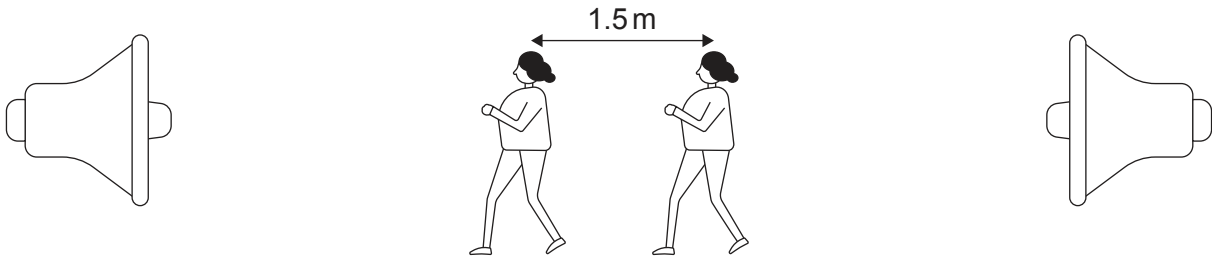

A student walking between the two loudspeakers finds that the distance between two consecutive sound maxima is 1.5 m. The speed of sound is  $300 \text{ m s}^{-1}$ .

What is  $f$ ?

- A. 400 Hz
  - B. 200 Hz
  - C. 100 Hz
  - D. 50 Hz
15. A pipe containing air is closed at one end and open at the other. The third harmonic standing wave for this pipe has a frequency of 150 Hz.

What other frequency is possible for a standing wave in this pipe?

- A. 25 Hz
- B. 50 Hz
- C. 75 Hz
- D. 300 Hz

16. A longitudinal wave is travelling through a medium. The variation with distance  $d$  of the displacement  $x$  of the particles in the medium at time  $t$  is shown.

Which point is at the centre of a compression?

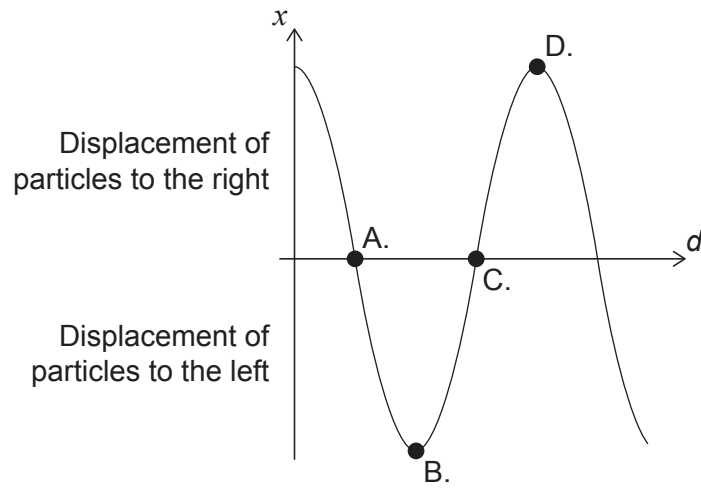

Turn over

17. A variable resistor is connected to a cell with emf  $\epsilon$  and internal resistance  $r$  as shown. When the current in the circuit is  $I$ , the potential difference measured across the terminals of the cell is  $V$ .

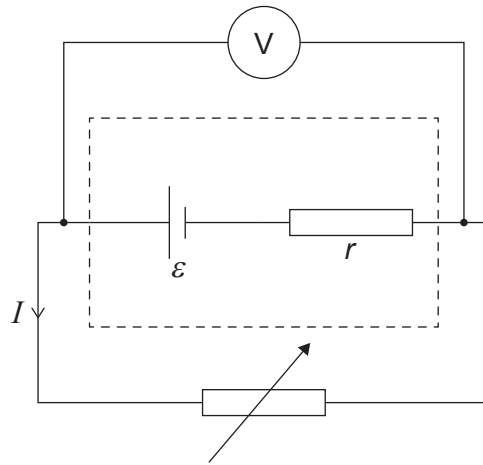

The resistance of the variable resistor is doubled.

What is true about the current and the potential difference?

	Current	Potential difference
A.	greater than $\frac{I}{2}$	greater than $V$
B.	less than $\frac{I}{2}$	greater than $V$
C.	greater than $\frac{I}{2}$	equal to $V$
D.	less than $\frac{I}{2}$	equal to $V$

18. Two identical wires X and Y are connected with a switch to a cell of negligible internal resistance as shown. The electrons in wire Y have a drift speed  $v$  when the switch is open.

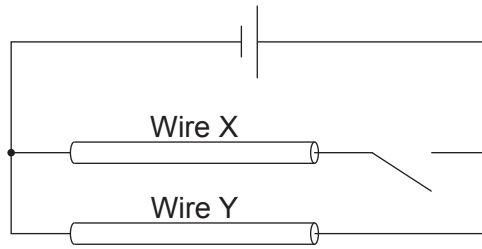

The switch is closed.

What is the drift speed of electrons in wire X?

- A.  $\frac{v}{2}$
  - B.  $v$
  - C.  $2v$
  - D.  $4v$
19. Three point charges,  $+Q$ ,  $+Q$  and  $-Q$ , are fixed at the three corners of a square.

What is the direction of the electric field at the fourth corner?

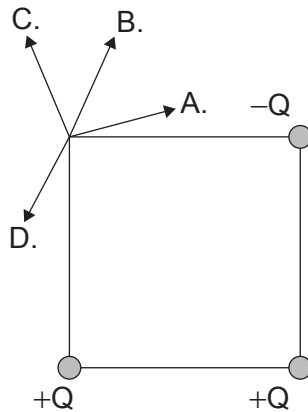

Turn over

20. Two resistors of equal resistance  $R$  are connected with two cells of emf  $\varepsilon$  and  $2\varepsilon$ . Both cells have negligible internal resistance.

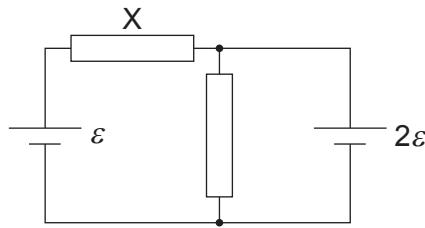

What is the current in the resistor labelled X?

- A.  $\frac{\varepsilon}{2R}$
  - B.  $\frac{3\varepsilon}{2R}$
  - C.  $\frac{\varepsilon}{R}$
  - D.  $\frac{3\varepsilon}{R}$
21. A negatively charged sphere is falling through a magnetic field.

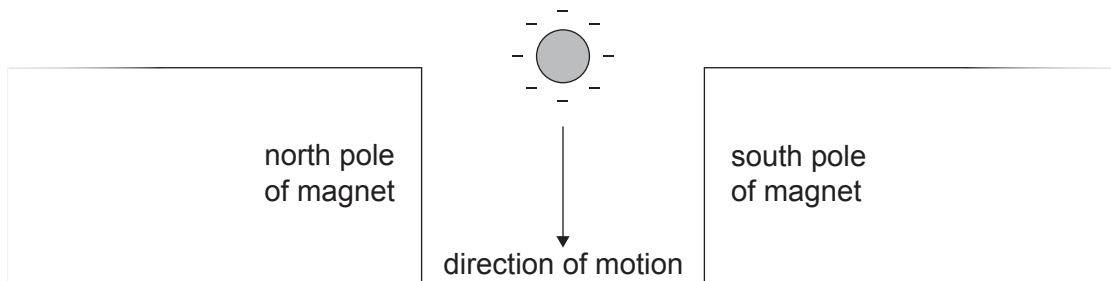

What is the direction of the magnetic force acting on the sphere?

- A. To the left of the page
- B. To the right of the page
- C. Out of the page
- D. Into the page

22. An electron is accelerated from rest through a potential difference  $V$ .

What is the maximum speed of the electron?

- A.  $\sqrt{\frac{2eV}{m_e}}$
- B.  $\frac{eV}{m_e}$
- C.  $\frac{2eV}{m_e}$
- D.  $\sqrt{\frac{2V}{m_e}}$

23. A mass on the end of a string is rotating on a frictionless table in circular motion of radius  $R_1$  and undergoes an angular displacement of  $\theta$  in time  $t$ .

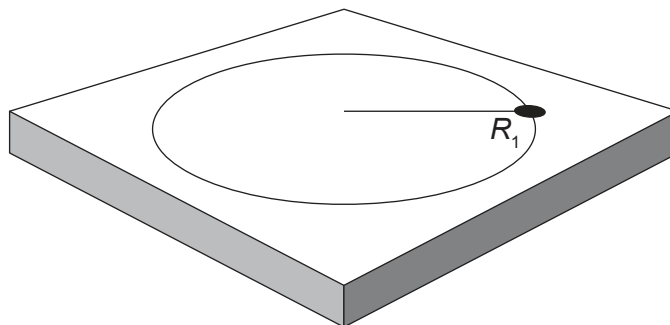

The string tension is kept constant, but the angular displacement of the mass is increased to  $2\theta$  in time  $t$ . The radius of the motion changes to  $R_2$ .

What is  $R_2$ ?

- A.  $\frac{R_1}{4}$
- B.  $2R_1$
- C.  $4R_1$
- D.  $R_1 \times R_1$

Turn over

24. A nucleus of platinum (Pt) undergoes alpha decay to form an osmium (Os) nucleus as represented by the following reaction.

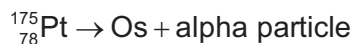

What are the number of protons and the number of neutrons in the osmium nucleus?

	Number of protons	Number of neutrons
A.	74	93
B.	76	93
C.	74	95
D.	76	95

25. A car engine has a useful power output of 20 kW and an efficiency of 50%. The engine consumes  $1 \times 10^{-5} \text{ m}^3$  of fuel every second. What is the energy density of the fuel?

- A.  $2 \text{ MJ m}^{-3}$
- B.  $4 \text{ MJ m}^{-3}$
- C.  $2 \text{ GJ m}^{-3}$
- D.  $4 \text{ GJ m}^{-3}$

26. The gravitational field strength at the surface of the Earth is often taken to be  $9.8 \text{ N kg}^{-1}$ .

The use of this value to calculate the weight of an object **above** the surface of the Earth is

- A. a paradigm shift in our understanding of gravity.
- B. an attempt to model gravitational fields.
- C. an outcome from a peer review.
- D. an approximation used for estimation purposes.

27. A student measures the count rate of a radioactive sample with time in a laboratory. The background count in the laboratory is 30 counts per second.

Count rate / counts per second	Time / s
150	0
90	20

What is the time at which the student measures a count rate of 45 counts per second?

- A. 30s
  - B. 40s
  - C. 60s
  - D. 80s
28. The following reaction is proposed for the collision of a proton p and a neutron n.

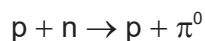

The neutral pion  $\pi^0$  consists of an up quark and an anti-up quark.

Which conservation law does this equation violate?

- A. Baryon number
- B. Charge
- C. Lepton number
- D. Strangeness

Turn over



29. Wind generator X has a maximum power output  $P_x$  for a particular wind speed. For the same wind speed, wind generator Y has a maximum power output  $P_y$ .

The blade radius of Y is three times the blade radius of X. Y is twice as efficient as X.

What is  $\frac{P_y}{P_x}$ ?

- A.  $\frac{3}{2}$
  - B.  $\frac{9}{2}$
  - C. 6
  - D. 18
30. A planet has an albedo of 0.30. A simplified energy balance for the planet is shown.

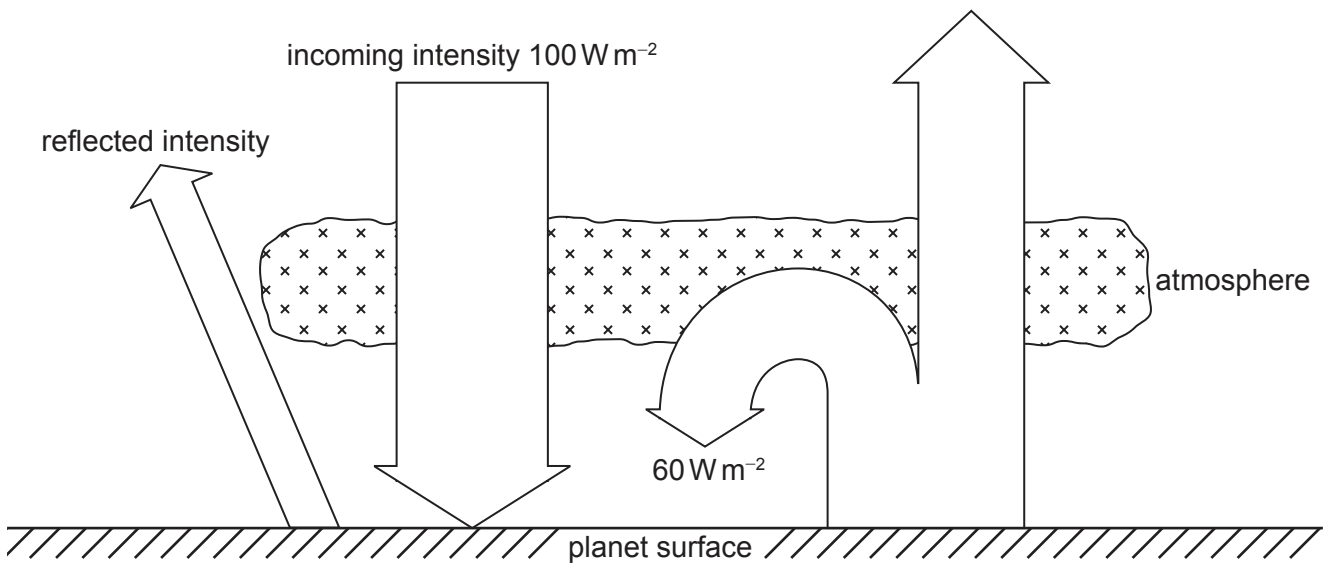

What is the intensity radiated by the surface of the planet?

- A.  $70 \text{ W m}^{-2}$
  - B.  $90 \text{ W m}^{-2}$
  - C.  $100 \text{ W m}^{-2}$
  - D.  $130 \text{ W m}^{-2}$
- 
- References:
- © International Baccalaureate Organization 2023